

# HD TOUR PACK ADJUSTMENT KIT INSTALLATION INSTRUCTIONS AC-TP-HD-01

2009+ HARLEY DAVIDSON ULTRA CLASSIC AND ELECTRA GLIDE  
CLASSIC TOUR PACK

## TOOLS NEEDED:

1/2" SOCKET OR BOX END WRENCH

3/8" SOCKET OR BOX END WRENCH

5/32" ALLEN WRENCH

SOMEONE TO ASSIST YOU

## KIT INCLUDES:

2 - ADJUSTING BARS, LEFT AND RIGHT

4 - 1/4"-20 FLAT HEAD SCREWS

4 - 1/4"-20 HEX HEAD SCREWS

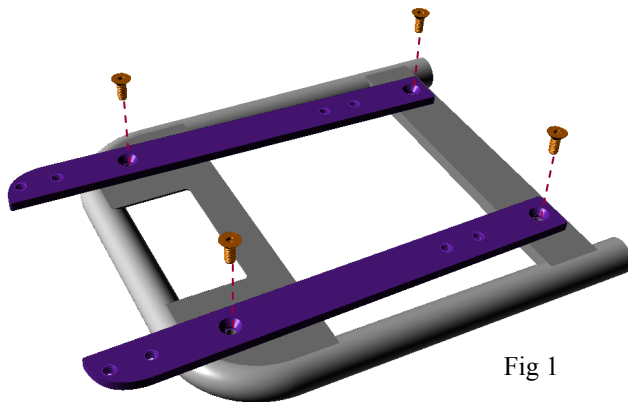

Fig 1

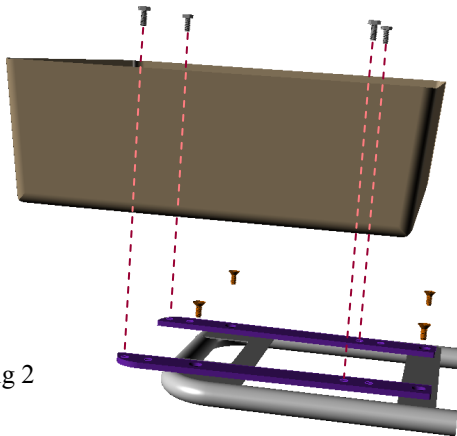

Fig 2

1. Open the Tour Pack and remove all of the contents.
2. Remove map bag and inner pack liner. Pack liner comes out quite easily once map bag is removed.
3. Remove the 4 bolts inside the tour pack that are located on top of the metal support plate that hold the tour pack to the luggage rack. Have your assistant hold the pack in place before removing the last bolt.
4. Gently tip the tour pack forward to expose the supporting luggage rack under the pack.
5. While your assistant holds the pack up, place the two adjusting bars on top of the supporting luggage rack. Use the 4 flat head screws supplied with the kit to mount the bars snugly to the support rack (see fig. 1).
6. Reposition the tour pack over the threaded holes in the adjusting bars at the 2" or 3" position and bolt it in place snugly (see fig. 2).
7. Replace the trunk liner and map case and the installation is complete!

**CAUTION:** We strongly recommend that the rider test ride this new configuration before hitting the road or carrying a passenger as this will change the motorcycle center of gravity slightly. The handling may feel a bit different than before and more so when loaded. Follow all manufacturer's loading limits.

**SARGENT**  
CYCLE PRODUCTS

1-800-749-SEAT FAX 904-354-7979  
[www.SargentCycle.com](http://www.SargentCycle.com)