

2003-2005 Yamaha FJR Backrest Installation Instructions

PART # BR-2059

IMPORTANT!

Read ALL instructions thoroughly prior to installation and use.



IMPORTANT!

Periodically inspect all bolts, connection points, and support bracket verifying that all connections remain secure and there are no signs of damage or wear. If problems are noted, discontinue use and contact the manufacturer immediately.



WARNING!

This backrest system has been tested at extreme pressures greater than what might be typically associated with rapid acceleration, however, for added safety the passenger should maintain a firm hold of grab handles or driver under such conditions. In addition, the driver should always signal the passenger before accelerating.

Limitation of Liability / Disclaimer:

Motorcycling is a dangerous activity that can result in serious injury or death. Please be advised that this product has NOT been tested under every conceivable condition. While every effort has been made to design a sturdy and reliable product, numerous unpredictable conditions and/or variables could occur during its use, resulting in possible property damage, personal injury or death. By proceeding with the installation, the purchaser acknowledges that these inherent dangers and unpredictable conditions exist. Furthermore, the purchaser understands that Sargent Seat Cover Co. / D.B.A. Sargent Cycle Products N.A. shall not be held liable for any direct, indirect, incidental, special, or consequential damages arising out of or in connection with the use of this product. Some states do not allow the exclusion or limitation of incidental or consequential damages, so this limitation or exclusion may not apply to you. If the purchaser does not agree to all terms of this limitation of liability/disclaimer, the product may return to Sargent Cycle Products N.A. in its original packaging (within 30 days) for a full refund of the purchase price (excluding shipping and handling).

SARGENT
CYCLE PRODUCTS

Yamaha FJR 1300 backrest installation instructions

BR-2059

Tools you need:
6mm hex wrench
13mm wrench

1

Check Parts included:

- Ⓐ Backrest
- Ⓑ Backrest Support Unit
- Ⓒ Center bolt
- Ⓓ Lock Nut and washer



2

CYCLE TAIL SECTION
BULKHEAD

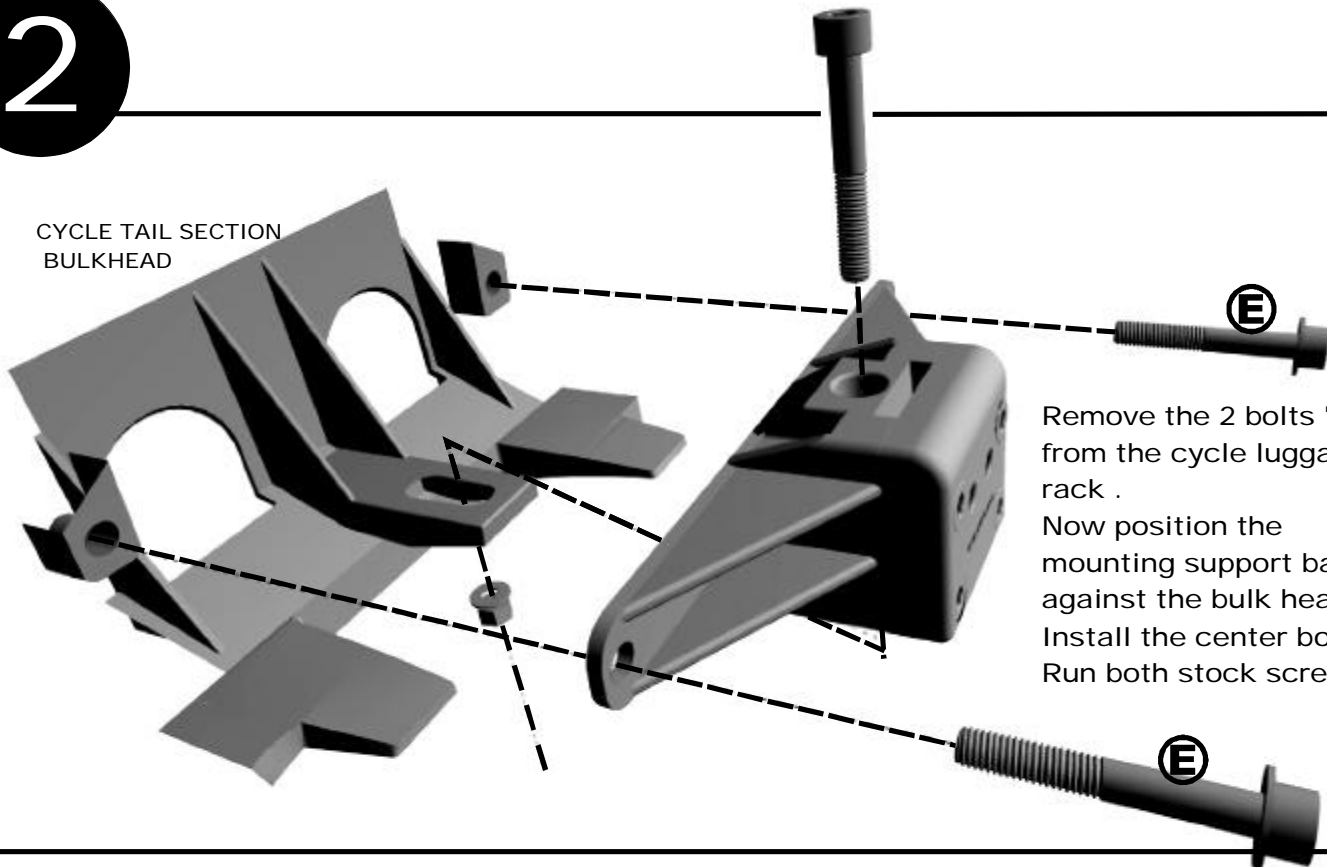

Remove the 2 bolts "E"
from the cycle luggage
rack .

Now position the
mounting support bar
against the bulk head.
Install the center bolt.
Run both stock screws in.

3

Tighten all 3 bolts and check
your installation for proper fit.
Now replace the seat , backrest
and RELAX!

*Once in use, you should periodically
inspect all bolts to insure
none have come loose.

Factory set screws,
Do not adjust

