

Yamaha FJR Backrest Installation Instructions

PART # BR-2102

IMPORTANT!

Read ALL instructions thoroughly prior to installation and use.



IMPORTANT!

Periodically inspect all bolts, connection points, and support bracket verifying that all connections remain secure and there are no signs of damage or wear. If problems are noted, discontinue use and contact the manufacturer immediately.



WARNING!

This backrest system has been tested at extreme pressures far greater than what might be typically associated with rapid acceleration, however, for added safety the passenger should maintain a firm hold of grab handles or driver under such conditions. In addition, the driver should always signal the passenger before accelerating.

Limitation of Liability / Disclaimer:

Motorcycling is a dangerous activity that can result in serious injury or death. Please be advised that this product has NOT been tested under every conceivable condition. While every effort has been made to design a sturdy and reliable product, numerous unpredictable conditions and/or variables could occur during its use, resulting in possible property damage, personal injury or death. By proceeding with the installation, the purchaser acknowledges that these inherent dangers and unpredictable conditions exist. Furthermore, the purchaser understands that Sargent Seat Cover Co. / D.B.A. Sargent Cycle Products N.A. shall not be held liable for any direct, indirect, incidental, special, or consequential damages arising out of or in connection with the use of this product. Some states do not allow the exclusion or limitation of incidental or consequential damages, so this limitation or exclusion may not apply to you. If the purchaser does not agree to all terms of this limitation of liability/disclaimer, the product may return to Sargent Cycle Products N.A. in its original packaging (within 30 days) for a full refund of the purchase price (excluding shipping and handling).

SARGENT
CYCLE PRODUCTS

Yamaha FJR Backrest Installation Instructions

See important warnings and disclaimers on page one.

Part # BR-2102

1

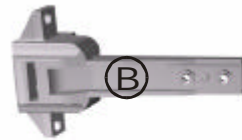

Check parts included:

- (A) Backrest
- (B) Support bracket
- (C) 20MM long bolts, qty. 2
- (D) Flat washers, qty. 2
- (E) 16MM long bolts, qty. 2
- (F) Lock washers, qty. 2



Tools you need:
8mm hex wrench

Assemble hardware

Remove seat from motorcycle.
Place support bracket into opening at the rear of the seat.
Start bolts (E) and lock washers (F) thru support bracket into back of seat as shown. Repeat using bolts (C) and washers (D) on the bottom of the seat.
Now tighten all 4 bolts.

2

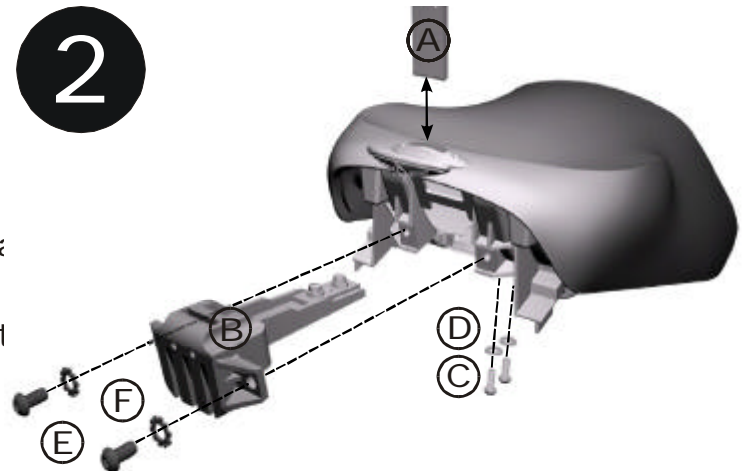

Factory set screws,
Do not adjust!

3 **Insert your new backrest and enjoy!**

Replace seat onto motorcycle. Lift World Sport logo slot cover and insert backrest (A) into slot until you hear a click. Now you are ready to go!

Important:
Once in use periodically inspect ALL bolts to insure they remain secure.

SARGENT
CYCLE PRODUCTS