





EM-5 BACKREST IMPORTANT WARNINGS

-  **IMPORTANT!**
Read ALL instructions thoroughly prior to installation and use.
-  **IMPORTANT!**
Periodically inspect all bolts, connection points, and Support Block Hardware verifying that all connections remain secure and there are no signs of damage or wear. If problems are noted, discontinue use and contact the manufacturer.
-  **IMPORTANT!**
Never use backrest, or any of its parts, as a cargo tie-down point. Excessive force produced by tie-downs can damage the backrest and will void the warranty.
-  **WARNING!**
This backrest system has been tested at pressures far greater than what might be typically associated with rapid acceleration or general use; however, for added safety, the driver and/or passenger should maintain a firm hold of handlebars, grab handles or driver. In addition, the driver should always signal the passenger before rapid accelerating.





Limitation of Liability / Disclaimer:

Motorcycling is a dangerous activity that can result in serious injury or death. Please be advised that this product has NOT been tested under every conceivable condition. While every effort has been made to design a sturdy and reliable product, numerous unpredictable conditions and/or variables could occur during its use, resulting in possible property damage, personal injury or death. By proceeding with the installation, the purchaser acknowledges that these inherent dangers and unpredictable conditions exist. Furthermore, the purchaser understands that Mark One Industries Inc. / D.B.A. Sargent Cycle Products North America shall not be held liable for any direct, indirect, incidental, special, or consequential damages arising out of or in connection with the use of this product. Some states do not allow the exclusion or limitation of incidental or consequential damages, so this limitation or exclusion may not apply to you. If the purchaser does not agree to all terms of this limitation of liability/disclaimer, the product may be returned to Sargent Cycle Products North America in its original packaging (within 30 days) for a full refund of the purchase price (excluding shipping and handling).

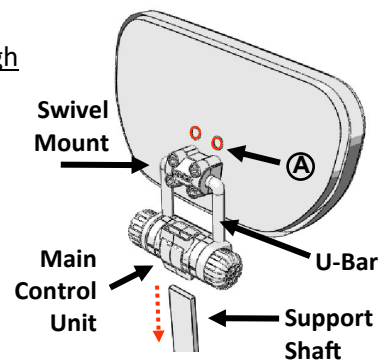
EM-5 BACKREST INSTALLATION AND OPERATION GUIDE

To install the EM-5 Backrest Assembly onto the Support Shaft, loosen the two knobs of the Main Control Unit and slide onto the Support Shaft. Tighten the knobs until snug. To adjust motions 1-3, loosen the two rubber knobs just enough to freely make adjustments. Tighten the rubber knobs securely to lock all positions. Swivel motion 4 is automatic and continuous. Motion 5 is affected by removing fasteners "A" to raise or lower pad on Swivel Mount using alternate holes (5 mm allen wrench).



-  Be sure that knobs are tight before each use.
-  When not using the backrest, always remove both the EM-5 backrest assembly and the support shaft assembly from the seat.
-  READ other important warnings above before use.
-  Always be sure that at least ¼ inch (6.35 mm) of support shaft is exposed at the top, above the main control unit, and at least ¼ inch (6.35 mm) of U-Bar is exposed below the main control unit.
-  Only make adjustments to the backrest main control unit while the motorcycle is at a stop and motor turned off. Never attempt to make adjustments while riding.

